

Double Module Rendered Open Fire 2

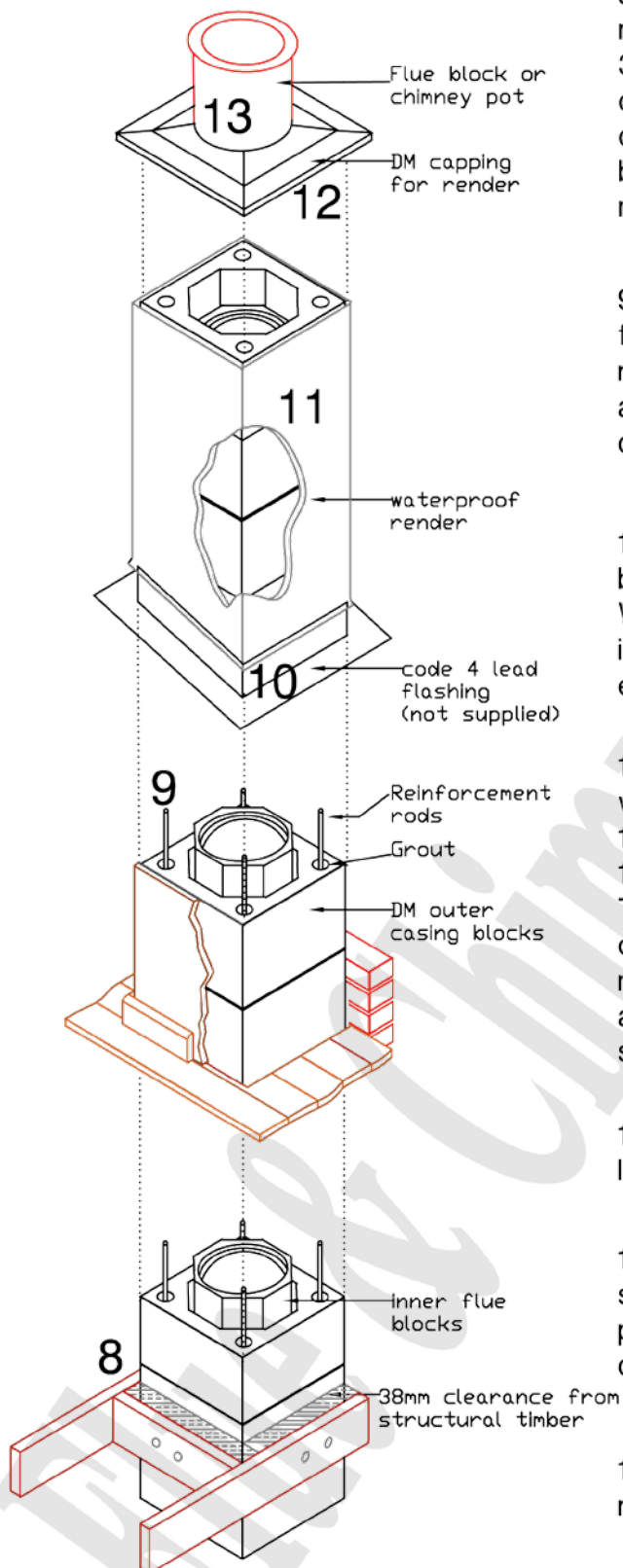

8) Where the chimney passes through a floor or roof, a sliding joint is made using mineral wool or similar non-combustible material. 38mm clearance must be maintained between the outer face of the chimney and any structural timber or loose combustible material. Floor boards, skirting boards, dado rails and other non-structural components may, however, be in contact with the chimney.

9) High tensile steel reinforcement rods will be required for all chimneys with a height that exceeds 1.4m above the roof line, 1.1m if the wind speed exceeds 44ms. These rods are available from Isokern and must be grouted (1:3 cement/sand) into the holes provided in the outer casings.

10) Code 4 lead flashing to be fitted at roof level as per building regulations. We recommend that you scorch a 5-10mm deep channel into the outer surface of the casings and fold in the top edge of the flashing.

11) Finish the outer surface of the casings above the roof with 2 part waterproof render. The recommended mix is: 1:2:5-6 cement:lime:sand for the undercoats. 1:2:8-9 cement:lime:sand for the final coat. The number of coats required will depend upon the degree of exposure, generally a two coat mix is acceptable. The mix may vary due to climate conditions, the thickness of any one coat should not exceed 15mm, and each subsequent coat should be reduced by approximately 3mm.

12) Isokern concrete capping to be lip glued onto the last casing.

13) Flashing with 1:3 cement and sharp sand to seal around the flue block or chimney pot. A chimney pot should be bedded at least 75mm into the outer casing block.

14) If you have any queries or questions please do not hesitate to contact Schiedel Isokern.